

MAPPING COMPETITION

Final submission

02 04 24

2nd edition

Through the Prism

May 2, 3 and 4, 2024

EXAT

FESTIVAL

PREFACE

What happens when **light, art, and technology meet**? A spectrum of new creations reveals the vibrancy and fascinating possibilities of **digital art**. In this **2nd edition**, EXALT Festival emphasizes the richness and exploration of **new exhilarating experiences**.

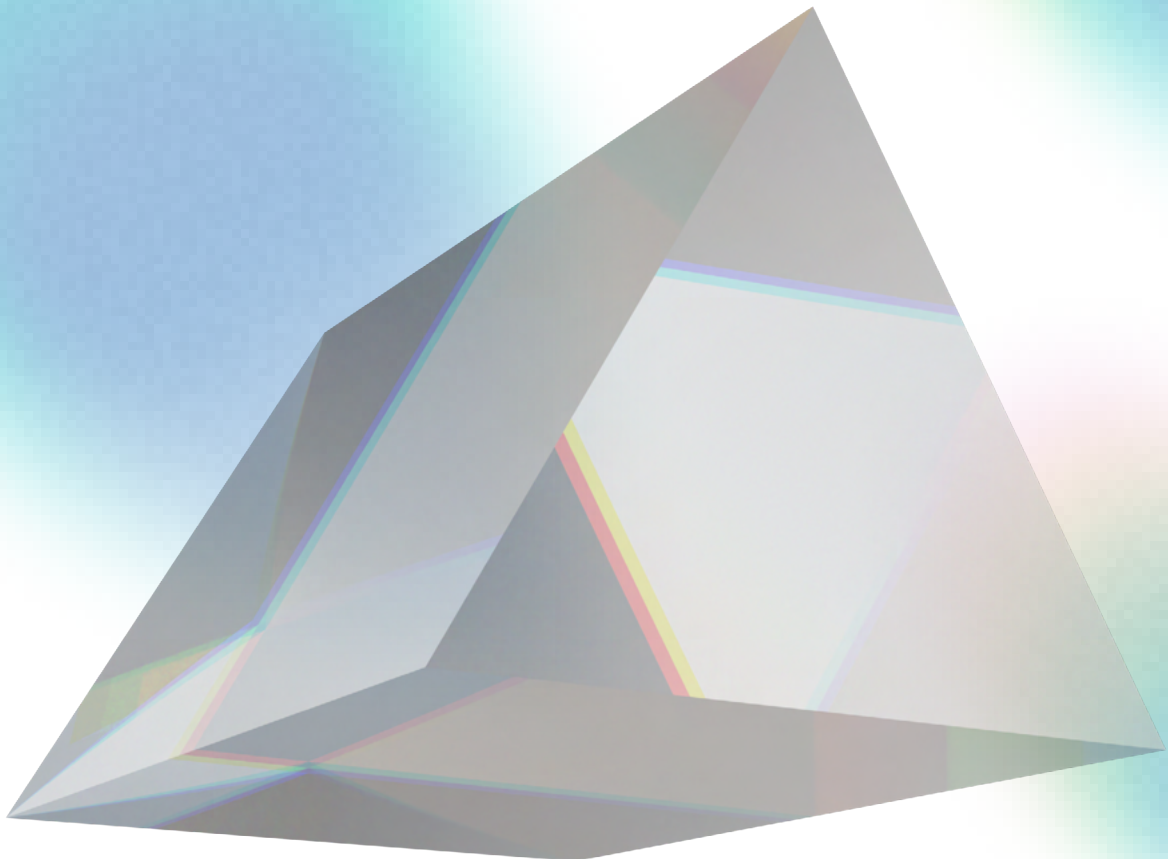

PRESENTATION

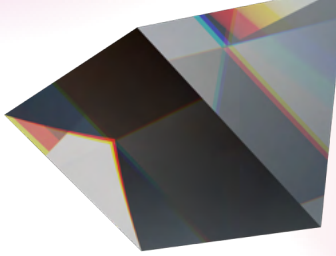

EXALT Festival is a **digital art event in Lyon** which aims to promote art and technology. Founded in 2022 by 10 in the Bachelor in Digital Creation program at MADE iN Sainte-Marie Lyon, EXALT Festival returns for a second edition with a **new team** and a **new theme**.

Bold, we are a collective of students with the ambition of **keeping EXALT Festival alive** and developing the Lyon scene of emerging digital creation.

EXALT Festival is an opportunity for emerging creators or artists to highlight artistic projects combining **creation** and **innovation**, where experimentation takes us to new horizons.

RETROSPECTIVE 1ST EDITION

Programming in
numbers

9

artistic proposals

8

outdoor video mappings on an
area of 141m²

10

artists and collectives

Our subscribers

2000

subscribers on social networks
(Instagram, Facebook, TikTok)

An event that brings
together

3

evenings

700

festival-goers (students, families,
art enthusiasts, etc.)

13

partners including Théoriz
Studio, Eurosono, Grim Edif,
Carré Bleu, Brewlab, La Caisse
d'Épargne, Sainte-Marie Lyon...

Instagram

5000

impressions on Instagram

1 team entirely dedicated
to the organization

10

people

50

volunteers

8

months of preparation

TikTok

20000

impressions on TikTok

WHERE? WHEN?

EXALT Festival will be held this year, from **May 2-4, 2024** on an exceptional site: the old departmental archives located **in the heart of the historic district of old Lyon**, offering a breathtaking view of the city.

FOR WHOM?

Are you a young creator? An emerging artist? A student? A **mapping** professional? Do you have a practice related to **animation, motion design, video editing** and you want to see your creation projected on a **less traditional** and **larger medium**?

If so, **apply** for this competition!



THE THEME

For this 2nd edition, **Through the Prism** is the theme selected by EXALT Festival.

The prism is an optical object which **breaks down** white light into a spectrum of vibrant colors, it **reveals** the unsuspected riches of light. Similarly, **digital art** acts as a **prism** through which we can explore and reveal the **diversity of human experiences, ideas, and emotions**. This theme invites us to consider digital art as a powerful tool that explores the **different perspectives** that make up our world.

EXALT Festival wants to highlight those who combine **imagination and technology**, transforming reality into something surprising, fascinating, and exhilarating.

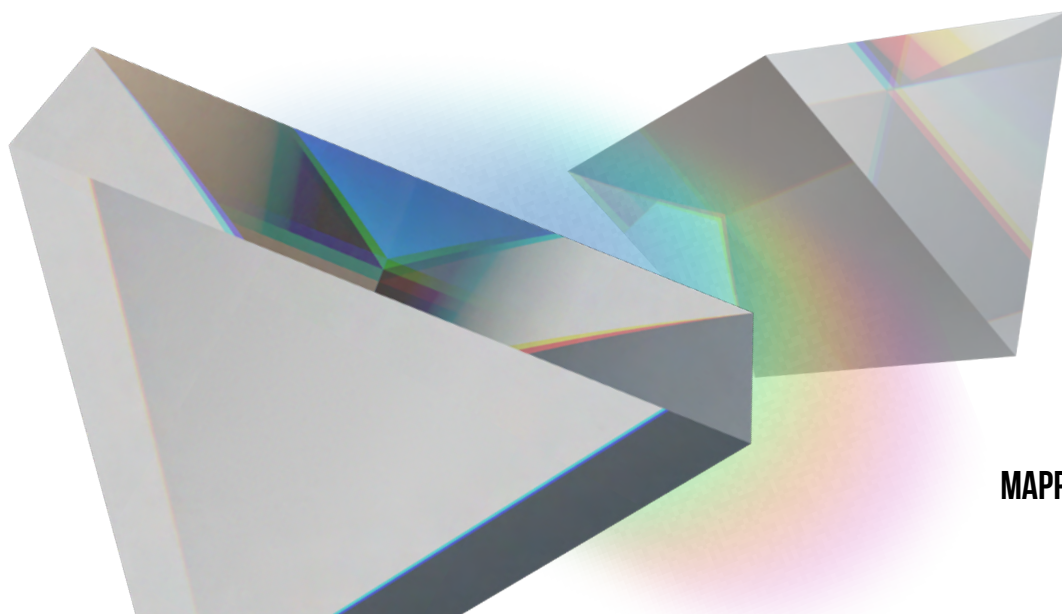

OUR RESEARCH

Different video **mapping projects** using the following techniques :

- Real shots
- 2D and/or 3D animation
- Motion design
- Mixed media: live shots, visual effects, motion design, or animation, ect...
- Animation created from creative programming

All projects must be accompanied by a **soundtrack**; if it is not original, make sure you have broadcasting rights within the framework of the festival.

Each proposal must be designed or **adaptable** to the projection surface planned for the competition, presented in the appendix.



TERMS OF PARTICIPATION

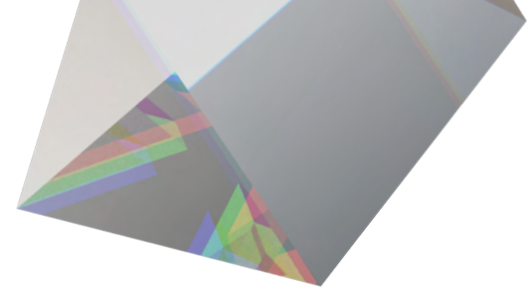

The competition is open to students, artists, creators, and professionals based in **France or abroad**, working in the fields of mapping, audiovisual, animation, digital arts, graphic design, video games, etc.

The creation can be made **individually or collectively**. Each participant can submit one or more proposals.

The creation must be **designed for the festival's "helical staircase"** projection surface from the matrix provided and focused on the **theme** of the festival. *Through the Prism*, in its symbolic or semantic form.

Participants undertake to own all rights related to the work (images and sound). EXALT Festival cannot be held responsible in the event of a dispute.

Participants authorize EXALT Festival to use their work as follows:

- Broadcast of the creation during the evenings on **May 2, 3 and 4, 2024**.
- A video recording will be produced and used to promote EXALT Festival and the work: distribution in whole or in part on the internet and social networks, or during presentations of the project as part of various events, without limitation of duration or geographical area.

The broadcast of works as part of EXALT Festival does not commit participants to being present during it. However, if you wish to attend the festival, you will be given a pass and an invitation for 2 people on the evening of your choice. Also, a rest area and catering will be made available to you.

We guarantee **all the technical and material support necessary for the dissemination of the works** in order to present them in optimal conditions (projection, cabling, sound system).

SELECTION CRITERIA

- Maximum duration: 3 minutes
- Relevance of the proposal to the theme
- Artistic qualities.

1ST STEP : REGISTRATION

To participate in the competition, simply register on our website

www.exalffestival.com

We will acknowledge receipt of your request and send you the **technical file : projection surface matrix**, authorized audio and video format and codecs, as well as **the list of documents and files to be provided at the time of final submission**.

-> Registration deadline : **February 1, 2024**



2ND STEP : FINAL SUBMISSION

The **final creation accompanied by the files and documents** requested after registration will be sent via a download link (WeTransfer / DropBox / OneDrive / Google Drive...) to the following address : **partenariat@exalffestival.com**

-> Visit to the festival premises:

March 30, 2024 (not obligatory)

-> Deadline for submitting the final file :

April 2, 2024

3RD STEP: DISTRIBUTION AND COMPETITION

All selected creations, corresponding to the selection criteria and sent within the stipulated deadlines, will be projected during the evenings of the festival, **May 2, 3 and 4, 2024**.

Each participant will be credited on the festival program and will see their work promoted on our communication media.

The creations will be submitted to a public vote and a professional jury.

Following the votes, the jury will award 3 prizes and one creation will be awarded the public prize. As the entire project is voluntary, the amount or nature of the prizes awarded are still to be determined and will be communicated to participants as soon as possible. In addition, the creations selected and distributed will not be eligible for any compensation other than the prizes awarded as part of the competition.

ANNEXES

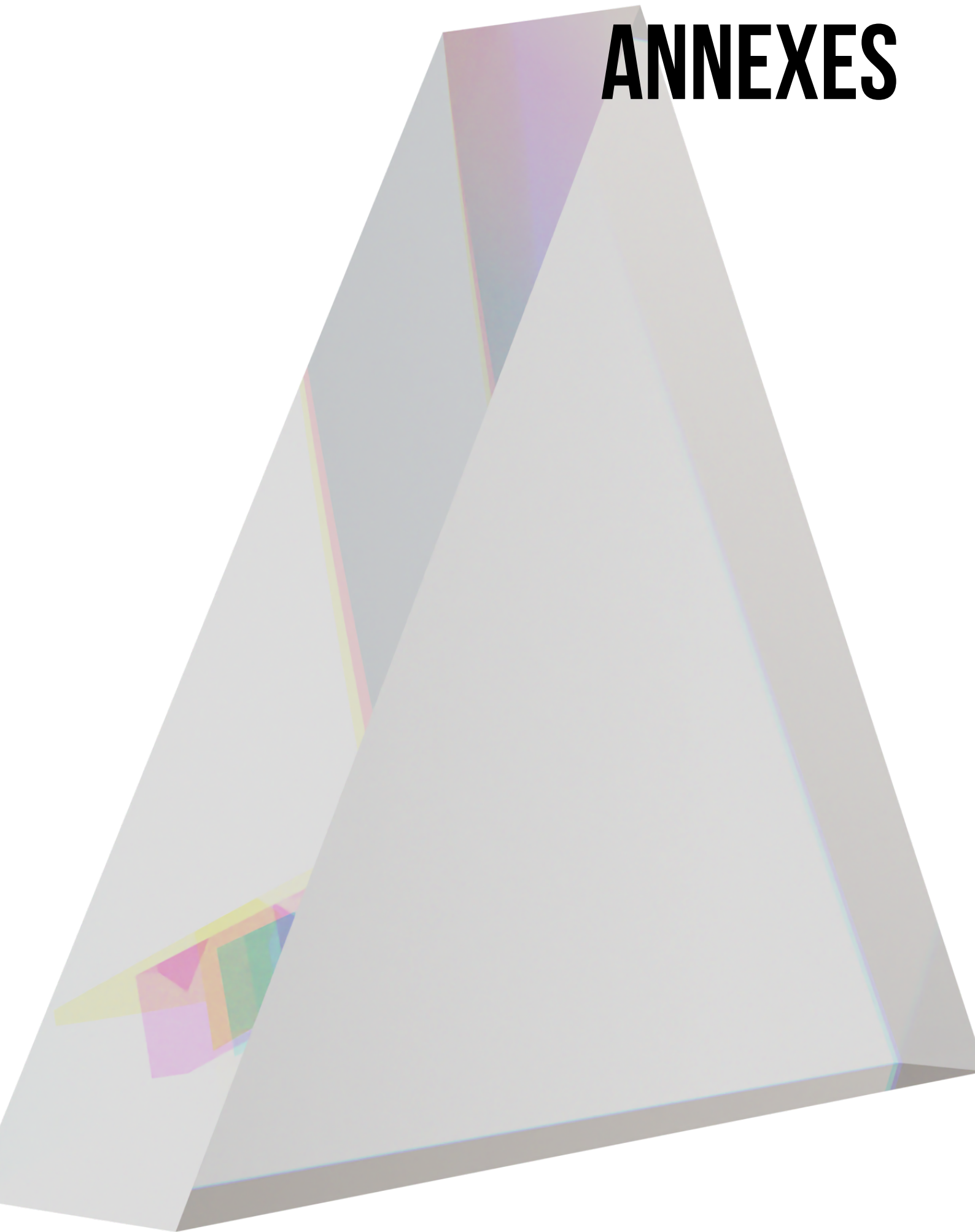

PROJECTION SURFACE

Located on a central square of the festival with **6 surfaces** available, the projection surface is made up of a section of wall and a helical staircase for a total surface area of **141 m²** including **76 m² of useful surface area for mapping**.

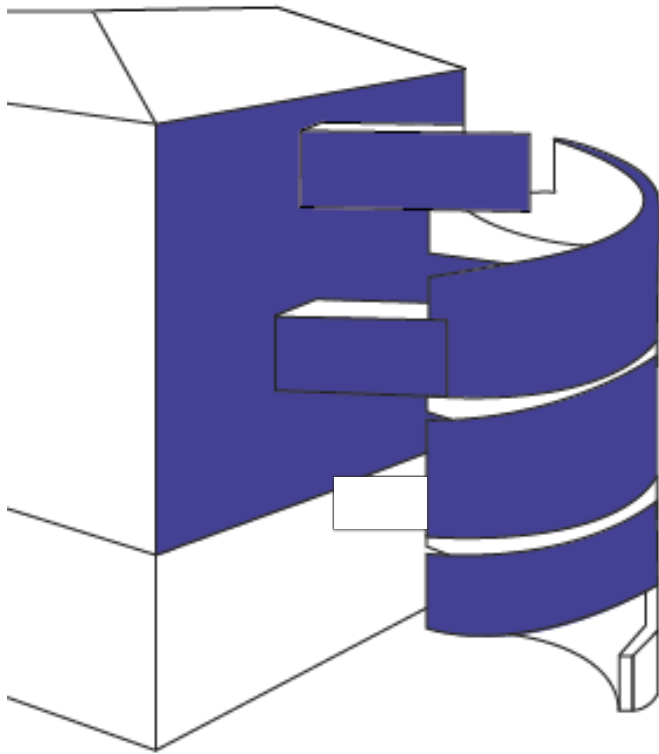

↑
15 m

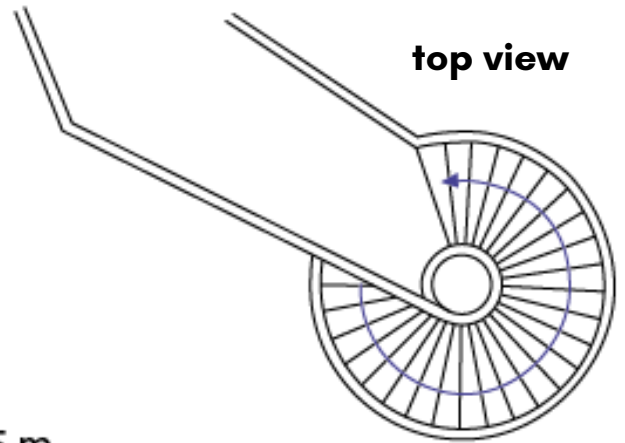

 projection surface

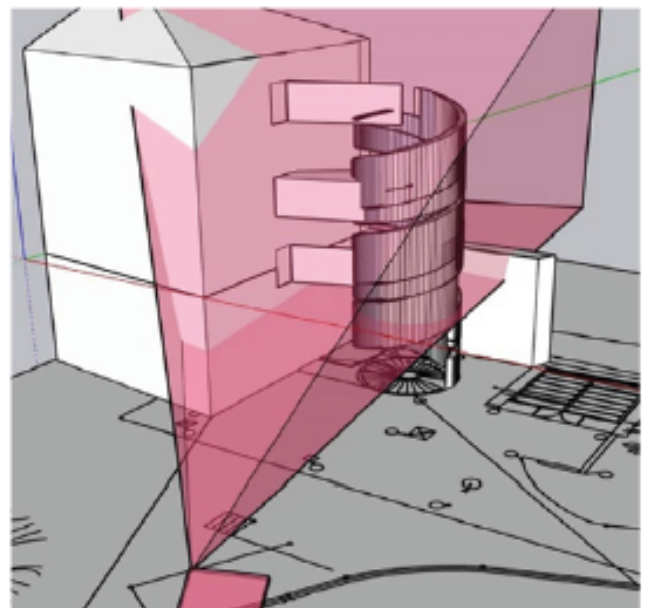

position of the
video projector



EXALT

FESTIVAL

MAPPING COMPETITION

2ND EDITION

THROUGH THE PRISM

MAY 2, 3 AND 4, 2024

For any questions regarding your application or the organization of the festival, do not hesitate to contact us.

 E-mail : partenariat@exaltfestival.com

 Website : www.exaltfestival.com

 Instagram : [@exaltfestival](https://www.instagram.com/exaltfestival)

 Facebook : [Exalt festival](https://www.facebook.com/Exalt festival)

 LinkedIn : [EXALT Festival](https://www.linkedin.com/company/EXALT Festival)

Salomé Gonzalez

Partnership Manager

 06.64.80.76.74

Shola Hamma

Partnership Officer

 07.69.29.58.72